

**RESEARCH, DEVELOPMENT
AND TESTING
NATIONAL INSTITUTE FOR
ELECTRICAL ENGINEERING**

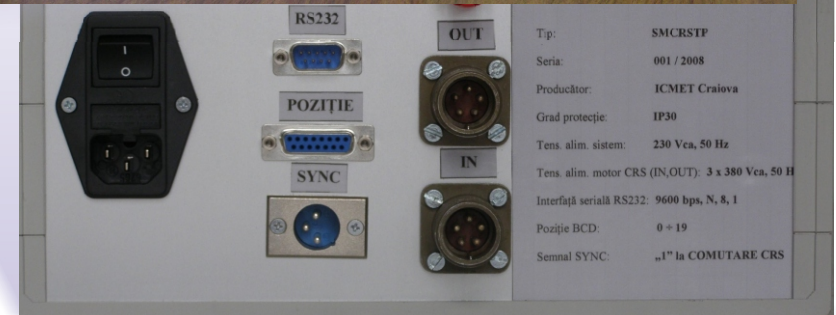

Variation diagram for absorbed active power

LOAD TAP CHANGER MONITORING SYSTEM FOR POWER TRANSFORMERS

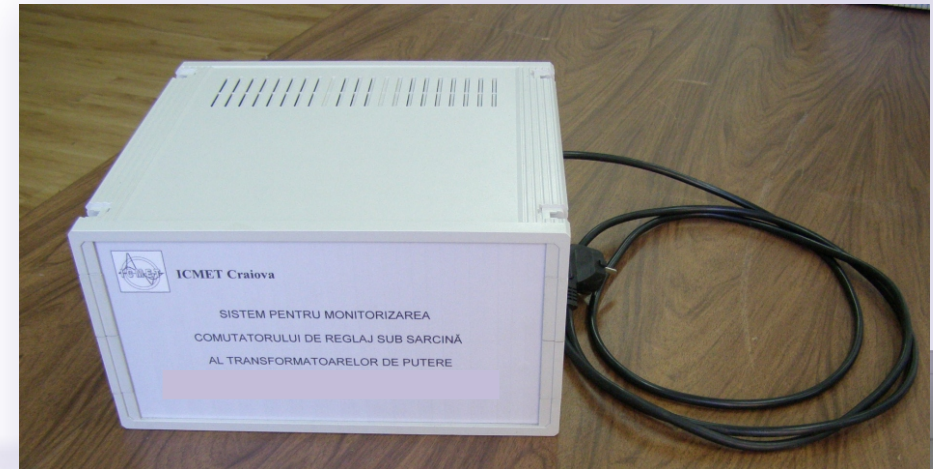

**Calea București 144
200515 Craiova, Romania
Phone: +40 351 404 888; +40 351 404 889
Fax: +40 251 415 482; +40 351 404 890
E-mail: market@icmet.ro
testing_services@icmet.ro; calibration_services@icmet.ro
www.icmet.ro**

The CRS-Mon type system is a digital system with microcontroller, intended for monitoring the operation of power transformer on load tap changers (OLTCs), as regards the mechanical wear of their components. Within the period between two successive switchings of OLTCs the system acquires and sends serially, when receiving an acquisition request from the hierarchically higher level, the following characteristic quantities:

- number of initial tap
- number of final tap
- switching duration
- total number of switching operations
- average values of the phase currents of OLTC driving motor
- average values of the phase voltages of OLTC driving motor
- average value of the active power when switching
- instantaneous values of the current through one of the OLTC driving motor phases (optionally)
- instantaneous values of the active power absorbed by OLTC driving motor

The CRS Mon system can be used either independently by connecting it to a PC provided with a serial port RS 232 or integrated into a hierarchy system for power transformer monitoring by using the serial interface, by means of a converter RS232/RS485, thus implementing a SLAVE in this system.

With the acquired quantities, the variation diagram of the absorbed active power is plotted: this can be compared with the initial characteristic (fingerprint), got when commissioning the OLTC

TECHNICAL CHARACTERISTICS

- overall dimensions: (L x w x h): 291 mm x 345 mm x 152 mm
- protection degree: IP 30
- operating temperature range: -5 to 45°C (installation in closed electric switch box)
- supply voltage: ~ 230 V (±10%), 50 Hz
- maximum consumption: 115 VA
- supply voltage of OLTC driving motor: 3 ~ 380 V, 50 Hz
- measuring range of OLTC driving motor phase current: 0.5 A, accuracy ±10.5%
- measuring range of OLTC driving motor phase voltage: 0.250 V, accuracy ±1%
- measuring range of OLTC driving motor active power: 0.3450 W, accuracy ±2%
- 8 galvanically insulated inputs for SWITCHING IN PROGRESS and position BCD of OLTC
- galvanically insulated logical output SYNC (type OPEN COLLECTOR), "1" during a switching operation
- output for serial transmission of data, bidirectional RS232, transmission rate 9600 bps, data 8 bits, one START bit, one STOP bit, without parity control

OLTC driving motor

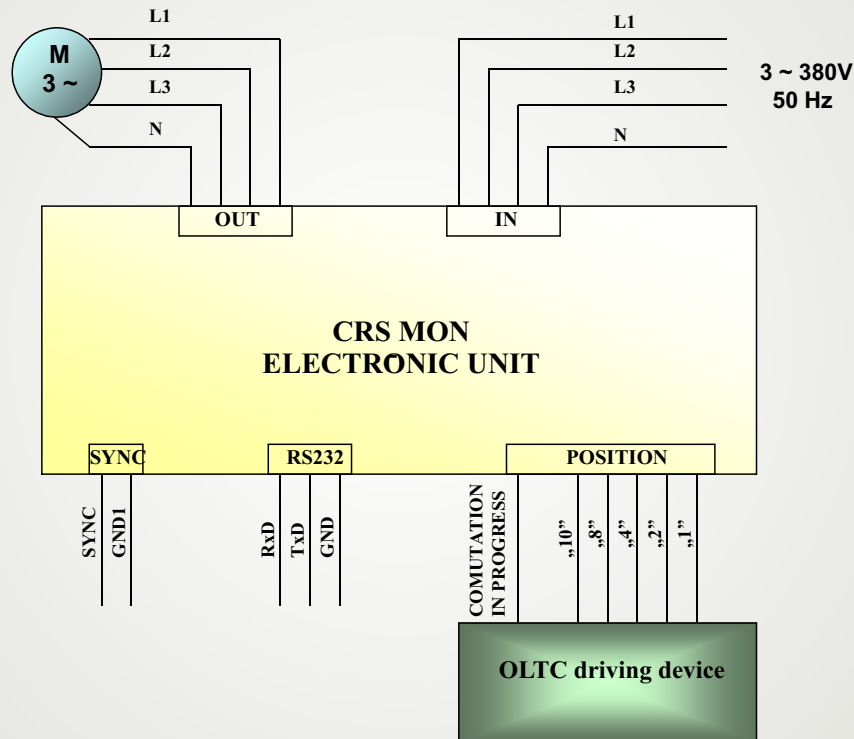

CONFORMITY

- The product complies entirely with the standards specified in SF ICMET-DIT no.5/2008:
- EN/IEC 61010 - Safety requirements for electrical equipment for measurement, control, and laboratory use
 - EN/IEC 61298 - Process measurement and control devices - General methods and procedures for evaluating performance
 - EN/IEC 61000-4-2 - Electromagnetic compatibility (EMC)- Part 4-2: Testing and measurement techniques - Electrostatic discharge immunity test
 - EN/IEC 61000-4-3 - Electromagnetic compatibility (EMC) - Part 4-3: Testing and measurement techniques - Radiated, radio-frequency, electromagnetic field immunity test
 - EN/IEC 61000-4-4 - Electromagnetic compatibility (EMC) - Part 4-4: Testing and measurement techniques - Electrical fast transient/burst immunity test
 - EN/IEC 61000-4-5 - Electromagnetic compatibility (EMC) - Part 4-5: Testing and measurement techniques - Surge immunity test
 - EN/IEC 61000-4-6 - Electromagnetic compatibility (EMC) - Part 4-6: Testing and measurement techniques - Immunity to conducted disturbances, induced by radio-frequency fields
 - EN/IEC 61000-4-11 - Electromagnetic compatibility (EMC) - Part 4-11: Testing and measurement techniques - Voltage dips, short interruptions and voltage variations immunity tests
 - EN 55022 - Information technology equipment -Radio disturbance characteristics -Limits and methods of measurement